

J. F. STARRATT.  
MACHINE FOR PRINTING FROM ENGRAVED PLATES.  
No. 14,295. Patented Feb. 19, 1856.

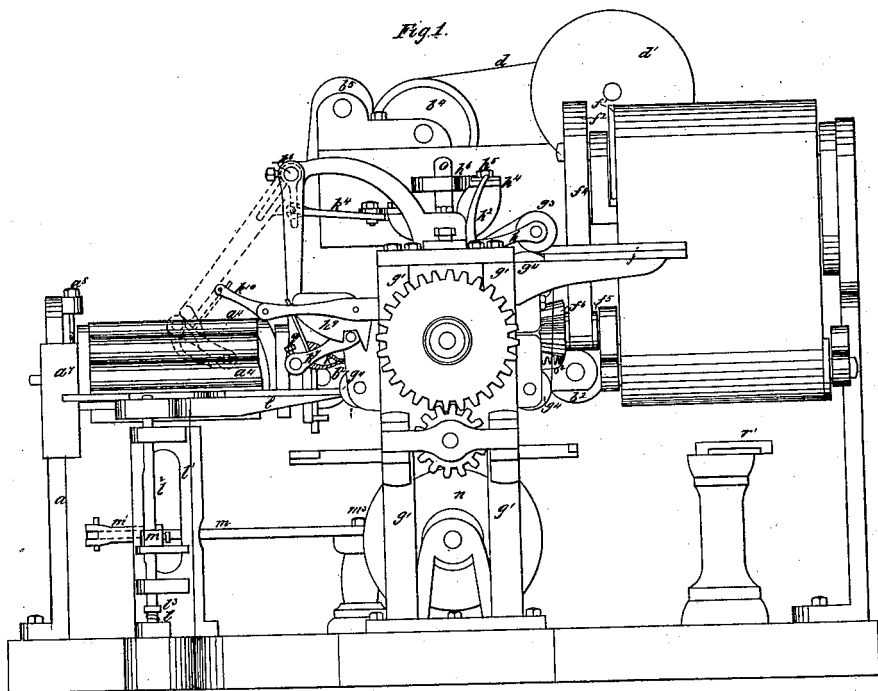

J. F. STARRATT.  
MACHINE FOR PRINTING FROM ENGRAVED PLATES.  
No. 14,295. Patented Feb. 19, 1856.

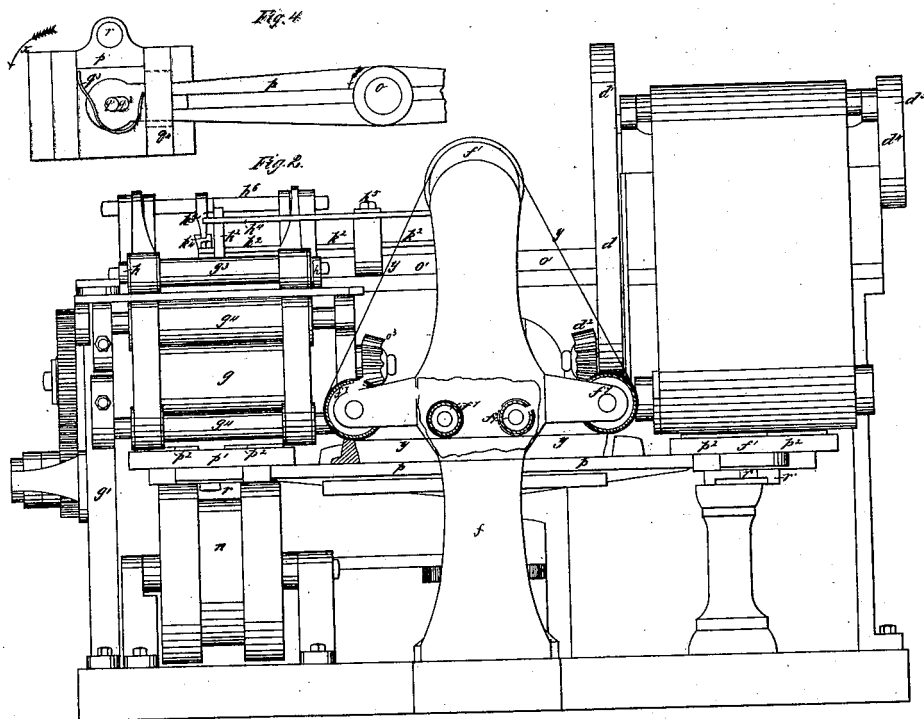
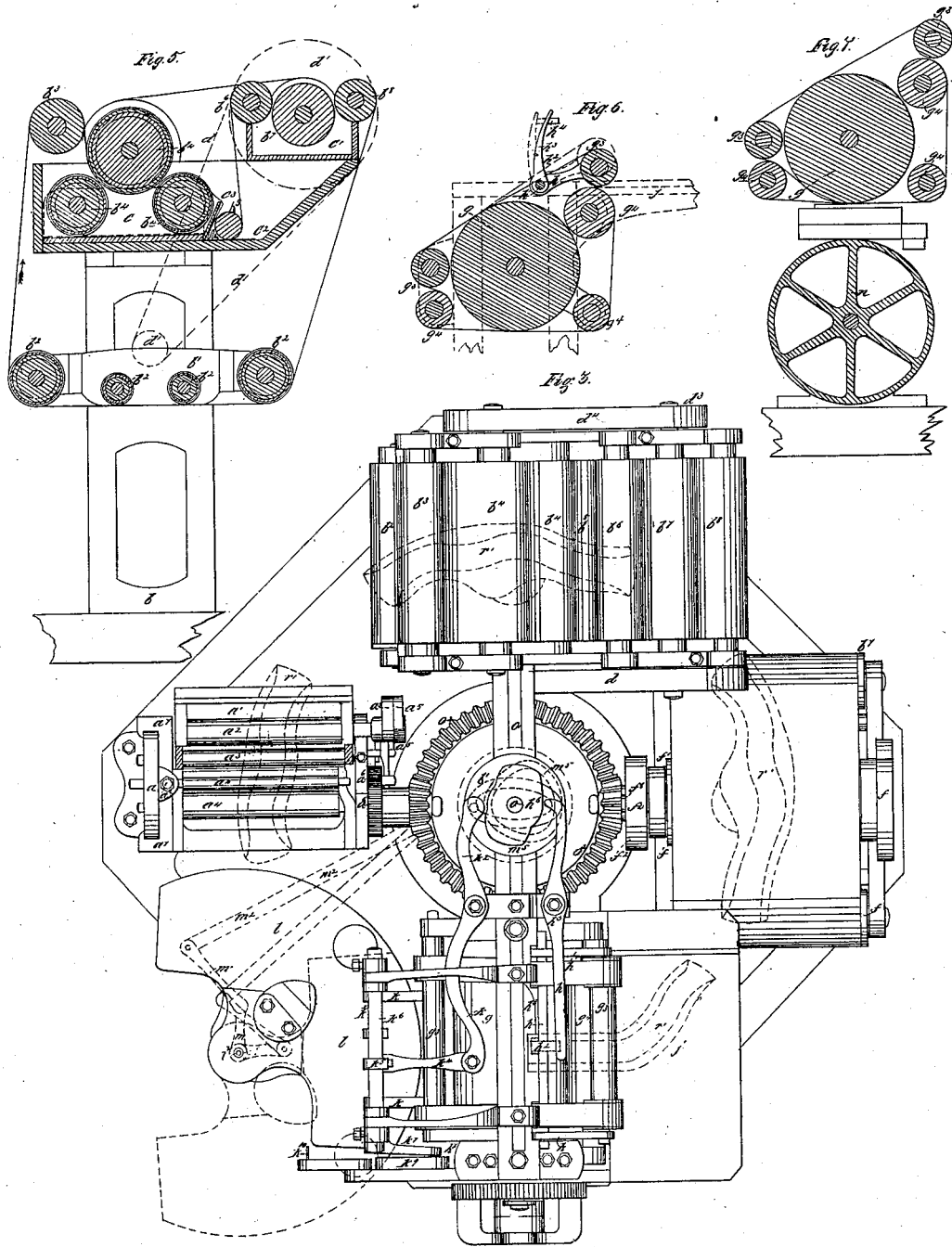

# UNITED STATES PATENT OFFICE.

JAS. F. STARRETT, OF NEW YORK, N. Y.

## MACHINE FOR PRINTING FROM ENGRAVED PLATES.

Specification of Letters Patent No. 14,295, dated February 19, 1856.

*To all whom it may concern:*

Be it known that I, J. F. STARRETT, of the city, county, and State of New York, have invented certain new and useful improvements in machinery for the purpose of taking impressions from engraved metallic plates and more especially from those on which music is engraved, such improvements being, however, applicable to other descriptions of printing.

In devising this machine I have endeavored to produce by machinery such effects as are now in usual practice produced by hand or hand tools, and have in some parts of the process given relative motions of the plate and wiping cloths very nearly such as are now produced by the hand of an operator. In my machine I have also made use of certain sub-arrangements now as a whole employed in the operations of printing by machinery preferring to use as far as possible contrivances already known as acting successfully rather than to invent new combinations which should produce the same results.

In the machine the inking, wet wiping, dry wiping, and printing apparatus are fixed upon a bed plate or frame, while the engraved plates are forced to travel from one to the other being subjected in proper order to the action of each, the whole being so arranged that there is no useless return of the plate from the end, to the commencement of the series; as it revolves from one to the other and the various subapparatus are as it were arranged in a circle so that the series commences and ends at the same point. The carrying out of this the main feature of my invention involved many difficulties in the overcoming of which many other features of invention were devised by me as hereinafter stated.

The nature of the first part of my invention therefore consists, in combining, inking, wet wiping, dry wiping, and printing apparatus or any two or three of them, with a traveling plate form mounted upon or near to the extremity of an arm revolving like the spoke of a wheel and carrying an engraved plate or its equivalent in such manner that it is handed from one to the other in proper order to be acted upon, and passes from the last to the first of the series, without any useless backward motion substantially as hereinafter specified, as the metallic plate must thus describe some

curved figure, which would cause it to pass between or beneath the impression cylinders in such manner that no correct impression could be produced.

The nature of the second part of my invention consists in causing the engraved plate or its equivalents carried upon a revolving platform and handed around as above described to pass underneath the impression cylinder in a line perpendicular to the axis of said cylinder substantially as hereinafter set forth, as in wiping the plates it is found desirable to impart to the cloth or plate or both such relative motions as shall rub one against the other on lines or curves differing at each rub, and as a similar motion is sometimes desirable in inking.

The nature of the third part of my invention consists in imparting to the plate a zig zag or irregular progressive motion while passing in contact with the dry or wet wiping cloths or both of them, or with the inking rollers substantially in the manner described.

The nature of the fourth part of my invention consists in imparting such zig zag motions by means of a flexible connection between the bed on which the engraved plates are placed or the engraved plates themselves and the traveling handing arm; in combination with a crooked guide track substantially as set forth.

The nature of the fifth part of my invention consists in permitting the plate to pass in a straight line in contact with the impression cylinder and in presenting it properly thereto by means of a flexible connection as aforesaid acting in combination with a stop on the carrying arm substantially as herein set forth.

The nature of the sixth part of my invention consists in wet wiping by means of a traveling wet cloth acting in combination with a plate which has imparted to it a zig zag progressing motion substantially in the manner described hereinafter.

The nature of the seventh part of my invention consists in combining with a printing apparatus an oscillating or rotating table so moved that sheets printed by different plates shall be piled in different piles thereon substantially in the manner described to save subsequent separation by hand; and the nature of the eighth part thereof consists in combining automatic vi-

brating chaps with tapes, which combination acts substantially in the manner and for the purposes hereinafter specified.

In describing my machine by reference to drawings I shall speak of it as having an inker, a wet wiper, a dry wiper and an im-

5  
10  
15

pressor, although it is obvious that some of these apparatus may be removed and one or more operators may act in their place without departing from the principles of my invention and also I describe it as having two arms and two sets of engraved plates secured thereon, it being clear that one only of such arms or many of them may be employed as convenience may dictate. I shall also describe very superficially and succinctly such parts as in their limited combinations are well known to those skilled in the art of printing by machinery.

20 In the drawings Figure 1 is an elevation of the whole machine from the printing cylinder side. Fig. 2 is an elevation of the same from the side of the dry wiping apparatus. Fig. 3 is a top view of the whole

25  
30

machine. Fig. 4 is a view from the under side of one of the traveling arms, platen and flexible connection. Fig. 5 is a section through the wet wiping apparatus, cloth rollers, and cisterns. Fig. 6 is a section through the printing cylinder and tape rollers showing the arrangement for wiping the sheet of paper. Fig. 7 is a section through the printing and supporting cylinders showing the platen, etc.

35 The same letters refer to the same parts in all the figures.

In constructing this machine a strong bed plate of any proper shape and construction is first provided, upon which are mounted

40  
45

at intervals appropriate frames, carrying the various subdivisions of apparatus and at or near the center is supported a strong upright shaft provided with cams and cog wheels, and also carrying arms upon which are fastened beds which carry engraved plates.

The inking apparatus which differs in no essential from those now in use is supported upon a standard  $a$ , and consists of an ink

50  
55  
60  
65

fountain,  $a^1$ , roller for carrying off portions of ink  $a^2$ , a roller  $a^3$  for delivering ink at intervals from the same to a series of rollers  $a^4$ ,  $a^4$   $a^4$  upon which it is distributed, and by the lower two of which it is imparted to the plate passing under them. The roller  $a^2$  has an intermittent rotary motion imparted to it by means of a ratchet apparatus  $a^5$ , acted upon by a cam or wiper attached to one or all of the traveling arms and the roller  $a^3$  has an intermittent vibrating motion derived from the same peculiarly shaped wiper while its rotary motion is imparted to it by either of the rollers with which it happens to be in contact. The series of rollers  $a^4$   $a^4$   $a^4$   $a^4$  receive their motion from cog

gearing  $a^6$   $a^6$  acting upon the central roller, the others being driven by friction, and the whole apparatus is free to rise and fall as it is carried by clasps  $a^7$  embracing the stand-

70  
75  
80

ard  $a$ , their motion being limited by a set and supporting screw  $a^8$ . Any usual combination of inking rollers may be substituted for these, and their motions may be derived from various mechanical equivalents of those described, as their precise relative arrangements or number, or motion, or manner of receiving such motion is immaterial, a good inking apparatus properly combined with other parts of the machine being the thing required.

Next in succession comes the wet wiper and washer with the resaturator. A standard  $b$  carries this apparatus, which consists mainly of cisterns of various rollers and means for driving some of them, and of a

85  
90  
95  
100  
105  
110  
115  
120  
125  
130

long piece of cotton or other cloth. Upon  $b$  is mounted a framing  $b^1$  which supports rubbing rollers  $b^2$   $b^2$   $b^2$  free to move on their axes, and above this frame are supported two cisterns  $c^1$ , which carry in appropriate journals a delivering roller  $b^3$  three wasting rollers  $b^4$   $b^4$   $b^4$  a sucking or immersing and resaturating roller  $b^5$  and three other rollers  $b^6$   $b^7$   $b^8$  for delivering and squeezing the superfluous moisture from the cloth. The rubbing and washing rollers are covered with elastic material in a manner hereinafter described and the rollers are so leveled that the plate to be wiped must pass in contact with the surface of a cloth passing beneath. This cloth is an endless one and after passing under the rubbers goes over  $b^3$  and is washed by passing between washing rollers partially immersed in cistern  $c$ , it is then delivered over the partition  $c^3$  into the cistern  $c^2$ , which may be dry or filled with liquid, where it passes under the roller  $b^5$  which has no journals, it then goes over  $b^6$ , under  $b^7$  and over  $b^8$ , having thereby its superfluous moisture squeezed out, and then descends to and passes under  $b^2$   $b^2$ , in a state fit for wet inking the inked plate which may be presented to it. The washing and rubbing rollers present certain difficulties in their operation which I have overcome by surrounding them in the first place with a layer of elastic material which is not too springy, and at the same time easily adapts itself to an engraved surface without too much pressure, such as feathers or curled hair, and as such a layer would soon become useless as it became saturated, I have covered it with a web of india rubber or some similar material which will resist the action of the liquid and at the same time conform itself to even the slightest alterations of shape of the cushion. These cushions and their elastic waterproof cover are clearly shown in sectional Fig. 5 through the washing and wet wiping apparatus. Positive 130

motion is imparted to  $b^7$  by means of a band, pulleys, and cog wheel,  $d$   $d^1$   $d^2$ , and its other end carries a pulley  $d^3$  imparting motion to a band  $d^4$  which in its turn drives the center washing roller  $b^4$ . The other rollers are moved either by the cloth or by friction.

The cloth is shown in Fig. 5, by a black line and arrows exhibit its direction of motion the rollers of course moving in concert therewith.

Positive motion may be imparted to some of the rollers or to others of the series and in any convenient way other than that described, such changes not being material. The number of rollers may also be altered, or various known devices may be substituted for them, or the relative arrangement of parts may be altered and still my invention will be unchanged as a rubbing, a washing, and a resaturating and squeezing apparatus, in connection with the rubbing cloth are the essentials, and not particular kinds of such apparatus. Roller  $b^5$ , is moreover employed to insure the sinking of the cloth and a very fair result as far as resaturating is concerned may be attained without it, it is a convenient accessory not an essential part of the apparatus.

The dry rubbing apparatus which follows next in order is mounted upon a standard  $f$  properly supported on the bed plate, which carries near its upper extremity a roller  $f^1$  receiving motion from a pulley  $f^2$ , driven by a band  $f^4$ , moved by a pulley  $f^5$ , mounted on a cog wheel  $f^5$ . Lower down upon this standard is secured a framing which supports the journals of four rollers  $f^7$   $f^7$   $f^7$   $f^7$ , each free to revolve and around all the rollers is applied an endless cloth whose edge is exhibited at  $y$   $y$   $y$  Fig. 2, the lower rollers, or some of them being so leveled that such cloth may rub the surface of a plate handed under it. The number, method of moving and relative position of these rollers are not material except in so far as they impart motion to a cloth and hold it in contact with a plate. This cloth may be removed when dirty and another applied in its place.

The impression apparatus last in the series consists essentially of a strong pressure cylinder between which, and the engraved plate, the paper is printed, it has as accessories one or more supporting rollers which bear up against the under side of the bed so as to insure pressure, also a table for holding the unprinted sheets; proper tapes for gripping and moving the paper, chaps or fingers for delivering each sheet as printed, and a table for holding the printed sheets.

The impressing pressure cylinder  $g$  is supported by a strong standard  $g'$ , and may have rotary motion imparted to it in any convenient way. Below it and firmly supported is located a supporting roller  $n$ , between which and the printing cylinder is

passed, a bed upon its arm; the bed or some projection therefrom resting upon said lower roller while the impression is taking place. Several small rollers may replace this large one. Near the impression cylinder are two sets of tape pulleys  $g^3$   $g^3$  and  $g^4$   $g^4$  each supporting endless tapes, these pulleys and tapes act as usual in printing machinery, and that one of  $g^3$  nearest the feeding table  $j$  is hung on vibrating arms  $h$   $h$  so that it may approach to and recede from its fellow  $g^4$ , so as to permit paper to be fed and seized it at proper intervals. These arms are carried by a rock shaft  $h'$ , to which is attached an arm  $h^2$  pressed upon by a spring  $h^3$  which tends always to hold  $g^3$  in contact with  $g^4$ , but at intervals this arm is moved in a contrary direction, parting the pulleys by means of a lever  $h^4$  pivoted at  $h^5$  whose inner extremity is acted upon by a revolving cam  $h^6$  attached to the upper end of the upright shaft which revolves near the center of the whole apparatus. As the sheet is delivered it is seized by chaps or pinching fingers  $k$  which at proper intervals approach the tape with their gains open seize the paper and retire, and when they have drawn it sufficiently out from the table open their jaws and deposit the printed sheet upon the table. The vibratory motion of these chaps is derived from a cam  $k^1$  on the center shaft acting upon a lever  $k^2$  which by means of a link  $k^4$  actuates a rock shaft arm  $k^5$ , whose shaft  $k^6$  vibrates the fingers or chaps. Their opening and closing movements are effected by an arm  $k^7$  having at its extremity a pin  $k^8$  which acts in combination with a vibrating cam or trigger piece  $k^9$  and also a rod  $q$  acted upon by an adjustable stop  $k^{10}$ , the chaps being returned to their pinching position by means of a spring shown in Fig. 3 at  $k^{12}$  which acts upon a rock shaft to which the lower jaws are attached and on which they vibrate. As the chaps open they drop the sheet upon a table  $l$  supported by a standard  $l'$ , upon a column or rocking shaft  $l^2$ , whose lower end is stepped in a socket  $l^3$  which is borne by a spring  $l^4$ , one end of this spring bears upon the bed plate, the other rests under a collar formed upon  $l^3$ . As weight is placed upon the table this spring is shortened and the table descends, as nearly as possible the thickness of a sheet for the weight of a sheet thereby presenting a surface whose level is nearly uniform for the deposition of the paper, sheet upon sheet. Any equivalent of this spring may be applied in place thereof such as an air vessel and piston or the steelyard known as the Roman, any weighing apparatus whose scale or pan descends gradually as weight is applied being proper for the purpose. This table  $l$  is moreover free to move in a horizontal plane upon its shaft  $l^2$ , as an axis, this motion being effected by means of an arm  $m$  secured to

the shaft, whose outer end is attached to a link  $m'$  secured to one end of a lever  $m^2$  pivoted at  $m^3$ ; on the other extremity of this lever a pin rests in a track or grooved cam  $m^5$  as the pin in lever  $k^2$  rests in track  $k'$  which is secured upon and rotates with the main center shaft. This cam is so formed in the present machine as to move the table by intermittent motion (having rests between) in such wise that when a sheet is printed from any of the plates on the arms it shall be received on one side of the table while at rest, and that the table should then vibrate receive on its other side another sheet, and then return again. As I have before stated however more arms than two and more than two differing plates may be in use, in such cases, my cam and my table must be adapted to the number of different sheets starting and stopping as often as the number of arms employed, during each revolution of any one of said arms, so that each different sheet may be laid upon its own separate pile, and where three or more arms are used I intend to adopt an interrupted rotation of the table instead of an interrupted vibration. In this connection I also state that the precise mechanical means applied to vibrate or rotate the table is a matter of no importance as I have devised many different ways of imparting such motion. My invention is upon the vibrating rotating table itself, and not in the mechanical devices for imparting that motion.

The center shaft  $o$  more than once alluded to has its lower end resting upon the bed plate or a journal fixed thereto, while its upper is confined by brasses to a strong cross bar  $o^1$ . This shaft has fixed thereon all the cams before referred to except those on the traveling arms and also a level wheel  $o^2$  properly toothed which imparts motion to the various cogs before referred to. This wheel has also in gear with it a beveled pinion  $o^3$ , secured to the shaft of the impression cylinder. As the latter is revolved, this pinion turns and moves the level wheel  $o^2$  and consequently the center shaft with its cams etc., and also the traveling arms, the whole apparatus therefore moves in time dependent upon the motions of the printing cylinder. This revolving center shaft has also firmly secured to it arms  $p$ , at whose extremities are attached beds  $p^1$   $p^1$  to which are secured engraved plates  $p^2$   $p^2$   $p^2$ . These plates therefore must travel in succession from inker to wiper, and from wiper to printer or impression mechanism. These beds upon which the engraved plates rest have at their lower sides pins or pivots  $q^1$  which enter slots  $q^2$ , Fig. 4, in or near the ends of the arms; they are therefore free to oscillate, rotate, or slide, out and in but are forced ordinarily to retain a certain position with their advancing edges in radii

drawn through the center of the upright shaft by means of spring  $q^3$  attached at one end to the arm and at the other to the bed in such manner, that it tends not only to shove the bed outward but also to twist it in the direction of arrow  $x$ , such torsion being limited by a stop  $q^4$  which is one side of a yoke or guide attached to the bed and inclosing the traveling arm. This stop when the machinery is built is so adjusted that the advancing edge of the bed shall be radial; or a set screw or wedge or some equivalent thereof may be applied so that this adjustment may be effected at any time.

Other and more complicated ways of attaching the bed to the arm have been devised by me, and the particular method of attachment is not essential, freedom of revolution or vibration and freedom to slide outward or inward along the arm and stoppage in a definite position being essential but irrespective of the precise mechanical devices employed for the purpose. To each bed is attached a pin or friction roller  $r$ , projecting below its general level and this pin when the arms or carriers revolve, enters crooked grooved tracks or ways  $r^1$  fixed upon standards and located beneath the ingoing or printing apparatus or either of them. As the arms turn, this track moves the pin and consequently the bed out and in and vibrating on its arm, rubbing it in many ways against the cloths which pass over it, or upon the inking rollers, if such a track is applied thereto, but when the bed enters between the impression cylinder and supporting rollers they seize it with its edge presented to them parallel to their own axes, and then as it is free to move grip it, and carry it through in a straight line, perpendicular to their own axes sliding it in and out upon the carrying arm. In place of a stop on the arm to limit in one direction the vibration of the bed I sometimes intend to fasten an open mouthed Y shaped groove on the bed plate in such wise that it shall by means of roller  $r$  entering its mouth bring the advancing edge of the bed into position.

In order to operate my machine, engraved plates are fixed upon the beds or upon blocks attached to the beds by wax or in any usual manner, the ink fountain is filled, so also is the resaturator, or the cistern with the usual alkaline mixture. The washing cistern is filled with a similar solution or with a liquid which by use in the resaturating cistern has become dirty the various rollers are then adjusted, so as to ink or wipe by being brought to the proper level and the pressure printing cylinder is by its adjusting screws, adjusted with reference to the supporting roller or rollers, so as to submit the paper to be printed to the proper pressure. Paper is placed on the feeding table and an operator stations himself there to feed a sheet as often

as required. Motion is now given to the printing cylinder and the whole machine by means of the various cogs, cams, and bands comes into action. The beds begin to traverse in their circular path carrying with them the engraved plates, and as each of the latter passes under the inker it receives a charge, thence coming under the wet wiper, it has the superfluous ink on the top of the plate removed by the wet cloth which is duly rubbed thereon by its own action and the zigzag progression of the plate. The plate then moves under the dry wiper and is prepared fully for being printed from, and it then approaches the printing cylinder; as it approaches, the tapes seize a sheet deposited between them, and carry it so that the sheet of paper and engraved plates meet between the printing cylinder and supporting rollers; the impression is now made, and the engraved plates pass on again to the inking apparatus while the printed sheet is seized by the delivering chaps and laid on the oscillating distributing table. Before another sheet has been printed by the plate on the next succeeding arm the receiving table oscillates so that sheets from each different engraved plate are delivered in separate piles.

30 In very fine engravings requiring careful inking it may be necessary sometimes to complete the wiping by hand; in such cases I intend to remove from the machine the dry wiper or perhaps both it and the wet wiper and place an operator in the locality occupied by them who with a cloth in his hand performs their work on each plate as it revolves, or operators may be stationed to perfect the work of the cloths.

40 Having thus described my machine I state that I claim as of my own invention therein:

1. One or more traveling platforms carrying attached to revolving arms and engraved plates from inking to wiping and then to printing apparatus in succession or to any two such, such apparatus being so arranged that the last and first of the series are next in succession and the arms revolve in the same direction continuously substantially in the manner and for the purposes specified herein.

50 2. I claim causing engraved plates which

are carried around in the circumference of a circle to be submitted to a printing cylinder in a line parallel to its own axes and not in radial lines of the circle in which the plates are carrier and then permitting them to pass in contact with said cylinder in lines perpendicular thereto and not in the arc of a circle substantially in the manner described.

3. I claim imparting to a plate or plates thus handled a zigzag or devious progressive motion while they are passing in contact with certain cloths or rollers substantially in the manner and for the purposes herein specified.

4. I claim the flexible connection between the plates or their beds, and the handing or carrying arms, as also grooved tracks or their equivalents acting upon beds so attached, and also these two in combination, substantially in the manner and for the purposes specified.

5. I claim such flexible connection in combination with a stop whereby an engraved plate carried upon a revolving arm is properly presented to the action of the impression cylinder substantially as herein specified.

6. I claim wet wiping an engraved plate by means of a traveling cloth acting in combination with a plate having a zigzag progressive motion substantially in the manner described.

7. I claim an automatic oscillating receiving table in connection with a printing apparatus wherein are printed in succession sheets, having different matter printed thereon so that similar sheets may be laid in the same pile substantially as hereinbefore specified.

8. I claim vibrating chaps or fingers in combination with the tapes for completing the delivery of a printed sheet and depositing it upon a table substantially as herein specified.

In testimony whereof I have hereunto subscribed my name in the city of New York on this 19th day of September A. D. 1855. 100

JAMES F. STARRETT.

In presence of—  
 GEORGE W. THORN,  
 ALFRED W. WALKER.